

PRODUCT SPECIFICATION FOR INFORMATION

PRELIMINARY SPECIFICATION

Product Name : Cavity Band Stop Filter

Part No : MSP-C4900-200MS-A-R1

■ History List

No.	Rev. No.	Description	Date	Author	Final Approver
1	R0	Draft	2023.03.08.	Jeffrey Jeong	Michael Jeon
2	R1	Changed finish to Black Powder Coating	2023.03.14.	Jeffrey Jeong	Michael Jeon
3					
4					
5					
6					

■ Mechanical Drawing

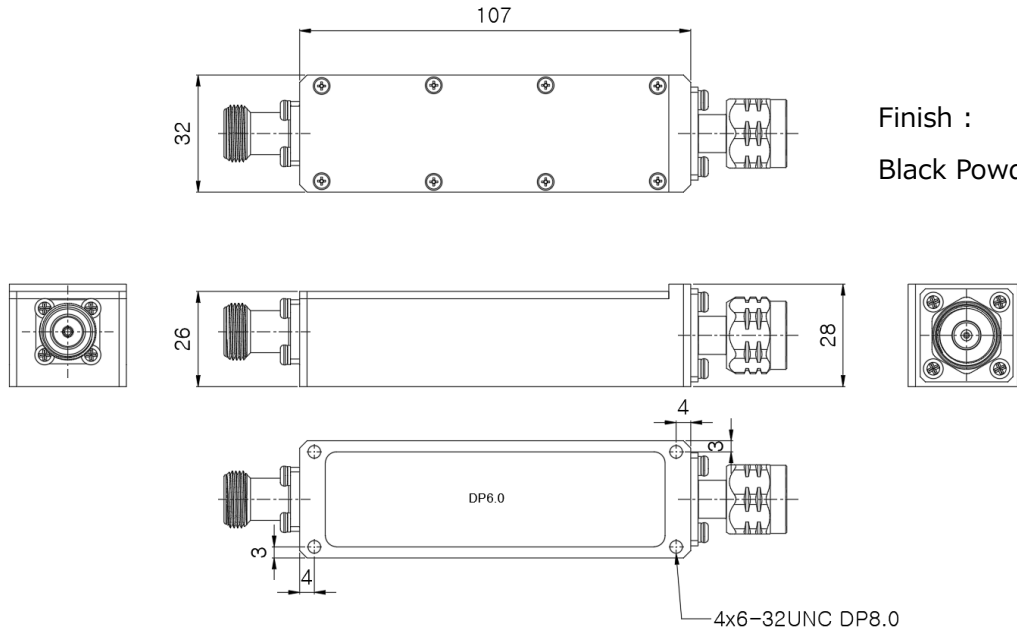

■ Electrical Specification

Parameter	Specification	Remark
1. Center Frequency	4900MHz	
2. Frequency Range	Fo ±100[4800 ~ 5000]MHz	
3. Pass Band	4000 ~ 4650MHz & 5150 ~ 5500MHz	
4. Insertion Loss	0.8dB Max.	
5. VSWR	1.5 : 1 Max.	
6. Rejection	50dB Min @ 4800 ~ 5000MHz	Proposed
7. Power Handling	10W Max	
8. Impedance	50Ω	
9. Size	107 X 32 X 28mm without T/S	
10. Weight	300g Max.	
11. Connectors	N-type(F), N-type(M)	
12. High Temperature Storage	+33°C ~ +71°C MIL-STD-810F Method 501.4 Proc I	
13. High Temperature Storage	-20°C MIL-STD-810F Method 502.4 Proc I	
14. Thermal Shock	-20 ~ +50 MIL-STD-810F 503.4 Proc I	
15. Humidity	95%±4% RH@30°C ~ 60°C	
16. Solar Radiation	Max. Intensity 1120@/m2 @ +49°C	
17. Blowing Rain	Wind Velocity 18m/s, Rain Rate 1.7mm/minit. Droplet size 0.5mm to 1.5mm in diameter MIL-STD-810F Method 506.4 Proc I	
18. Salt Fog	Salt Fog PH 6.5 to 7.2, Salt Solution Concentration 5±1% Salt Fog Fallout Rate 1-3ml/80cm2/h MIL-STD-810F Method 509.4	

Parameter	Specification	Remark
19. Blowing Sand	Air Velocity 18m/sec, Humidity <30% RH, Temperature +50deg, Sand Concentration $1.1 \pm 0.3g/m^3$ MIL-STD-810F Method 510.4 Procedure II	
20. Blowing Dust	Air Velocity 8.9m/sec, Humidity <30% RH, Dust Concentration $10.6 \pm 7g/m^3$, Temperature +23deg. & +50deg. MIL-STD-810F Method 510.4 Procedure I	
21. Degree of Enclosure	Distance 2.5-3meter, Splash Rate 12.5L/min Hose Nozzle Diameter 12.5mm IEC 60529 – IPX5	
22. Transportation Vibration	MIL-STD-810F Method 514.5 Procedure I, Cat. 7 & Cat. 4.	
23. Transit Shock	Shock Form – Saw-Tooth, Pulse Duration 11msec, Shock Amplitude 20g MIL-STD-810F Method 516.5 Procedure I	
24. Operational Altitude	15K Feet	
25. Storage Altitude	40K Feet	
26. MTBF	20,000HRS Max.	

※It is subjected to change with prior notice.

■ Simulation Curve

