

**Features:**

- Pass Band : 6.0G~ 10.0GHz
- Insertion Loss : 2.0dB
- Size : 9.1x5.0x0.5mm

**Absolute Maximum Ratings**

- Max. Input Power : +35dBm
- Storage Temperature : -55 ~ +85Deg.C
- Operating Temperature : -55 ~ +125Deg.C

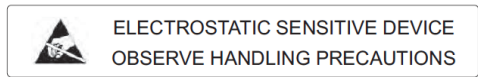

**Electrical Specifications (TA=+25Deg.C, 50Ω system)**

Parameter	Min.Value	Typical Value	Max.Value	Unit
Frequency Range	6.0 ~ 10.0			GHz
Insertion Loss (Fc)	-	1.62	2.0	dB
Ripple	-	1.41	2.0	dB
Attenuation	DC~@5GHz	30	-	dB
	@11.0GHz	30	-	dB
Return Loss	12.5	13.53	-	dB
Group Delay	-	1.36	2.5	ns

**Test Curve**

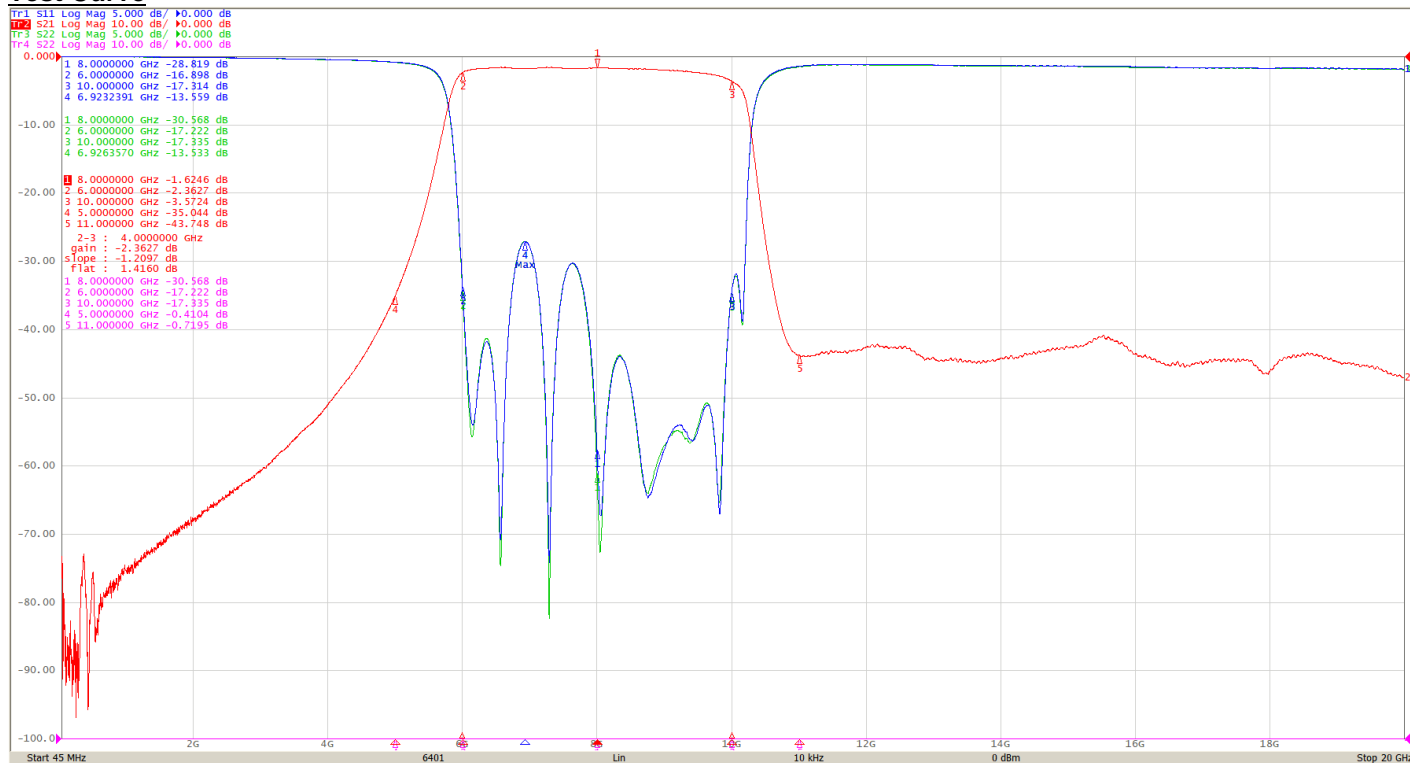

**Size**

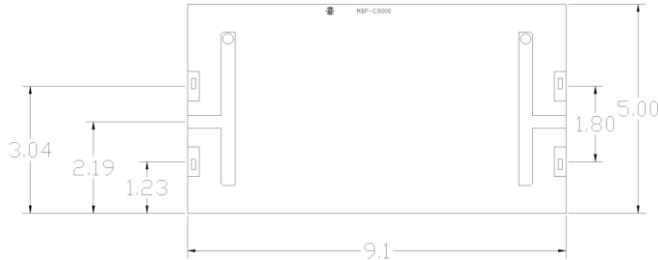

Remarks: Unit : mm, Tolerance :  $\pm 0.25$ mm  
 1. Chip bottom is gold plated and grounded.  
 2. Bonding pressure points are gold plated.  
 3. Don't bond on the through holes.

**Applications**

1. Assembly and Bonding Diagram. (Reference)

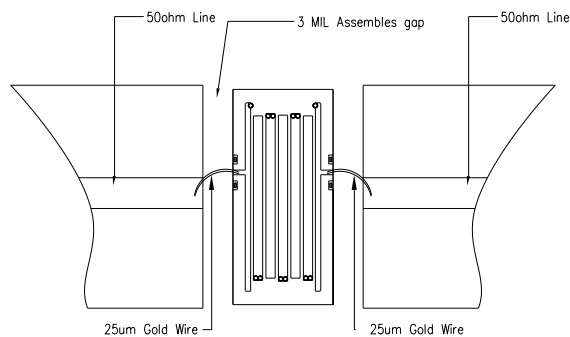

Assembly Diagram

2. The chip is back-metalized and can be die mounted with AuSn eutectic performs or with electrically conductive epoxy (for example ME8456).
3. The die should be assembled on carriers like Kovar or Mu-Cu which have same Coefficient of thermal expansion. (2.9ppm/°C) with Silicon, thickness 0.2mm max.
4. Handle the chips in a clean environment. DO NOT attempt to clean the chip using liquid cleaning systems.
5. Handle the chip along the edges with a vacuum collet or with a sharp pair of bent tweezers.