

Features:

- Pass Band : 1.5 ~ 1.95 GHz
- Insertion Loss : 2.7dB
- Size : 7.5x20.0x0.5mm

Absolute Maximum Ratings

- Max. Input Power : +35dBm
- Storage Temperature : -55 ~ +85Deg.C
- Operating Temperature : -55 ~ +125Deg.C

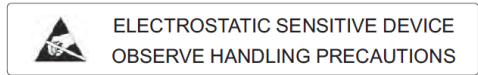

Electrical Specifications (TA=+25Deg.C, 50Ω system)

Parameter	Min.Value	Typical Value	Max.Value	Unit	
Frequency Range	1.5 ~ 1.95			GHz	
Insertion Loss (Fc)	-	2.23	2.7	dB	
Ripple	-	0.73	1.0	dB	
Attenuation	DC~@1GHz	30	37.87	-	dB
	@2.25GHz	30	34.45	-	dB
Return Loss	15.0	16.79	-	dB	
Group Delay	-	2.96	4.5	ns	

Test Curve

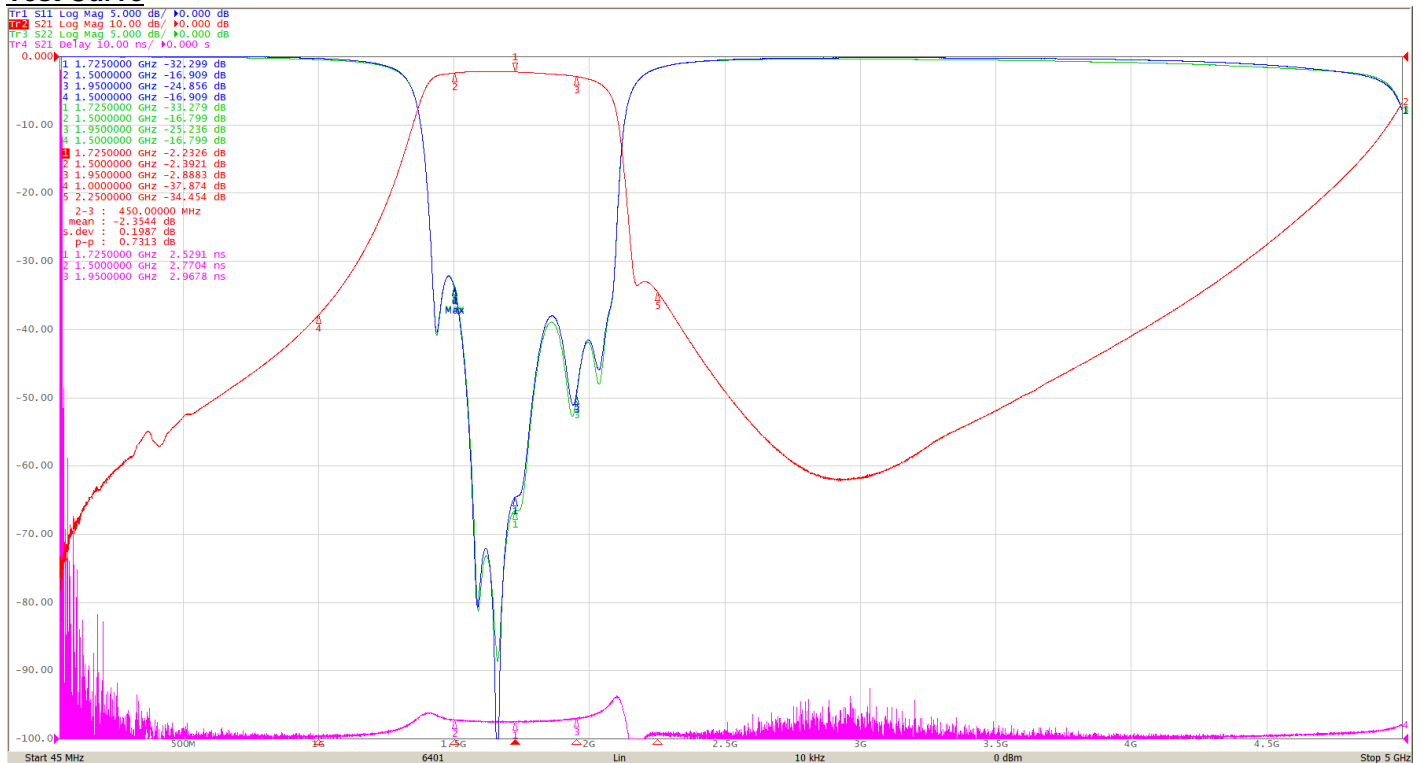

Size

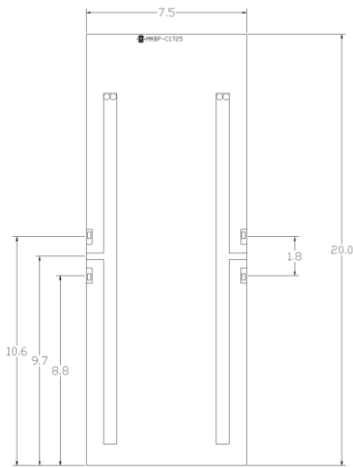

Remarks: Unit : mm, Tolerance : ± 0.25 mm
 1. Chip bottom is gold plated and grounded.
 2. Bonding pressure points are gold plated.
 3. Don't bond on the through holes.

Applications

1. Assembly and Bonding Diagram. (Reference)

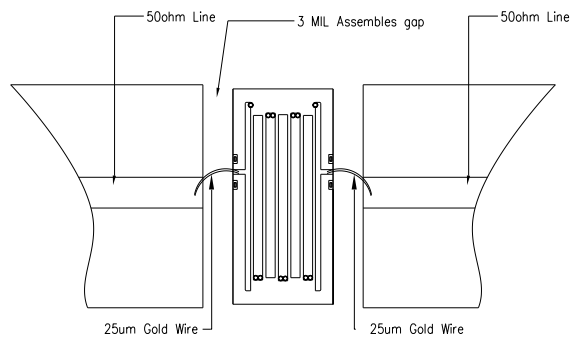

Assembly Diagram

2. The chip is back-metallized and can be die mounted with AuSn eutectic performs or with electrically conductive epoxy (for example ME8456).
3. The die should be assembled on carriers like Kovar or Mu-Cu which have same Coefficient of thermal expansion. (2.9ppm/°C) with Silicon, thickness 0.2mm max.
4. Handle the chips in a clean environment. DO NOT attempt to clean the chip using liquid cleaning systems.
5. Handle the chip along the edges with a vacuum collet or with a sharp pair of bent tweezers.