

PRODUCT SPECIFICATION FOR INFORMATION

FINAL SPECIFICATION

Product Name : MonoBlock BAND PASS FILTER

Part No : MBP-C4737.5_525MM-A

■ History List

No.	Rev. No.	Description	Date	Author	Final Approver
1	A	Draft	2021.01.29	Bryan Jeon	Michael Jeon
2	-	Added land pattern and Group Delay specification	2021.02.25	Bryan Jeon	Michael Jeon

■ Mechanical Drawing

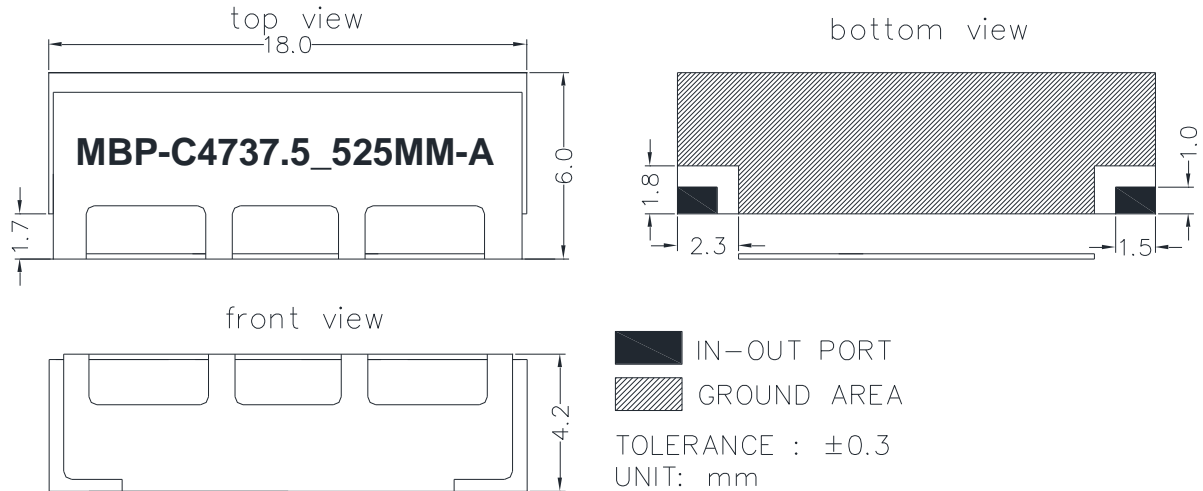

Note

1. Connector : SMD
2. Finish : Ag Plating

■ Electrical Specification

Parameter	Specification	Remark
1. Center Frequency[Fo]	4737.5MHz	
2. Bandwidth[BW]	Fo±262.5MHz(4475 ~ 5000MHz)	
3. Insertion Loss in BW	4.0dB Max	
4. Ripple in BW	0.7dB Max.	
5. Return Loss	15dB Min.	
6. Attenuation (Relative Value)	40dBc min @ DC~4200MHz	
	40dBc min @ 5250~7500MHz	
7. Group Delay	7ns Max.	
8. Input RF Power	1W Max	
9. Impedance	50Ω	
10. Operating temp	-40 ~ +85 °C	

■ Test Curve

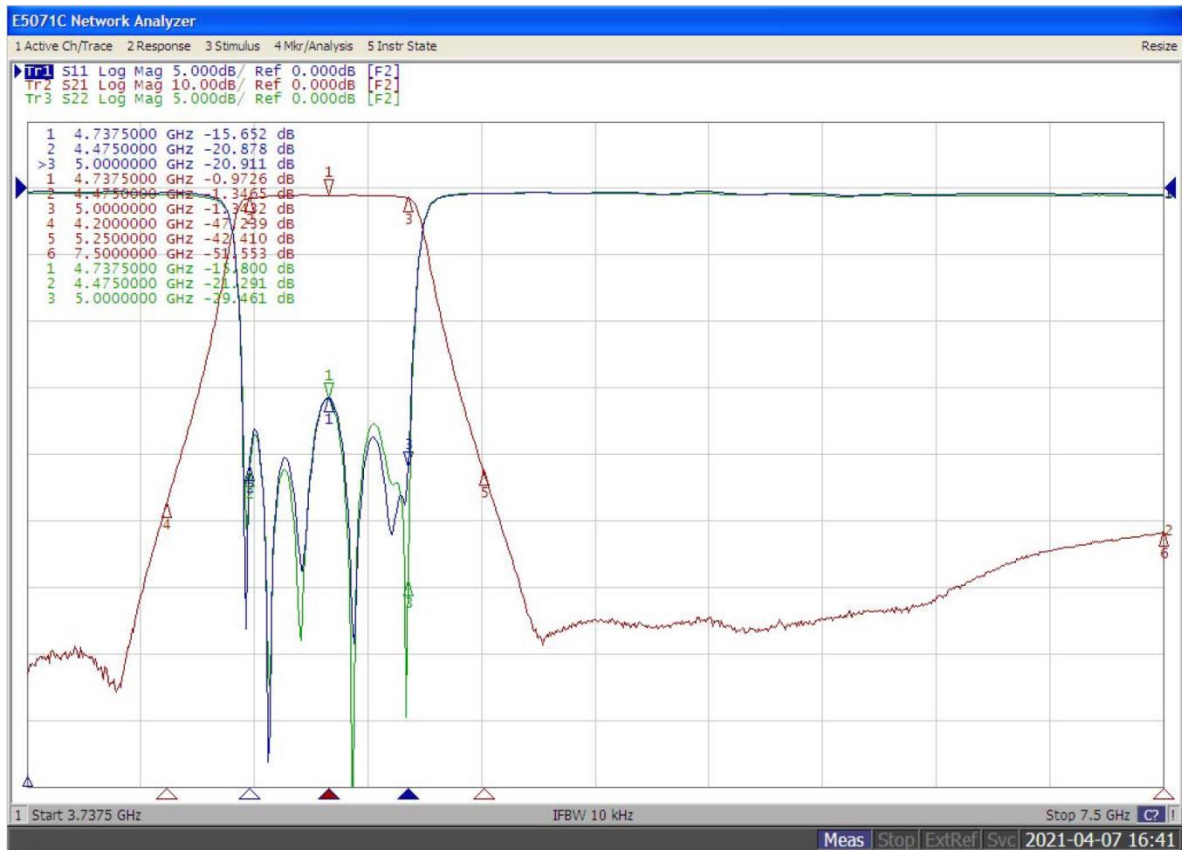

■ Recommended Land Pattern

